

# PHYSICS

## YEAR 12

### UNITS 3 & 4



## SOLUTIONS

### ***TIME ALLOWED FOR THIS PAPER***

Reading time before commencing work: Ten minutes

Working time for the paper: Three hours

### ***MATERIALS REQUIRED/RECOMMENDED FOR THIS PAPER***

#### **To be provided by the supervisor:**

- This Question/Answer Booklet; ATAR Physics Formulae and Data Booklet

#### **To be provided by the candidate:**

- Standard items: pens, pencils, eraser or correction fluid, ruler, highlighter.
- Special items: Calculators satisfying the conditions set by the SCSA for this subject.

### ***IMPORTANT NOTE TO CANDIDATES***

No other items may be taken into the examination room. It is **your** responsibility to ensure that you do not have any unauthorised notes or other items of a non-personal nature in the examination room. If you have any unauthorised material with you, hand it to the supervisor **before** reading any further.

## Structure of this paper

Section	Number of questions available	Number of questions to be answered	Suggested working time (minutes)	Marks available	Percentage of exam
Section One: Short answer	12	12	50	54	30
Section Two: Extended answer	6	6	90	90	50
Section Three: Comprehension and data analysis	2	2	40	36	20
			<b>Total</b>	180	100

### Instructions to candidates

1. The rules for the conduct of Western Australian external examinations are detailed in the *Year 12 Information Handbook 2018*. Sitting this examination implies that you agree to abide by these rules.
2. Write answers in this Question/Answer Booklet.
3. When calculating numerical answers, show your working or reasoning clearly. Give final answers to **three** significant figures and include appropriate units where applicable.

When estimating numerical answers, show your working or reasoning clearly. Give final answers to a maximum of **two** significant figures and include appropriate units where applicable.

4. You must be careful to confine your responses to the specific questions asked and follow any instructions that are specific to a particular question.
5. Spare pages are included at the end of this booklet. They can be used for planning your responses and/or as additional space if required to continue an answer.
  - Planning: If you use the spare pages for planning, indicate this clearly.
  - Continuing an answer: If you need to use the space to continue an answer, indicate in the original answer space where the answer is continued, i.e. give the page number. Refer to the question(s) where you are continuing your work.

**Section One: Short response****30% (54 marks)**

This section has **twelve (12)** questions. Answer **all** questions. Write your answers in the space provided.

When calculating numerical answers, show your working or reasoning clearly.

Give final answers to three significant figures and include appropriate units where applicable.

When estimating numerical answers, show your working or reasoning clearly. Give final answers to a maximum of two significant figures and include appropriate units where applicable.

Spare pages are included at the end of this booklet. They can be used for planning your responses and/or as additional space if required to continue an answer.

- Planning: If you use the spare pages for planning, indicate this clearly at the top of the page.
- Continuing an answer: If you need to use the space to continue an answer, indicate in the original answer space where the answer is continued, i.e. give the page number. Fill in the number of the question that you are continuing to answer at the top of the page

Suggested working time for this section is 50 minutes.

**Question 1  
marks)****(3**

An alien space ship is travelling at  $0.650c$  relative to the Earth. It sends a signal to the Earth's inhabitants by flashing a light every  $0.270$  seconds in the ship's frame of reference. Calculate the time between each flash of light from the Earth's frame of reference.

$t = \frac{t_0}{\sqrt{1 - \frac{v^2}{c^2}}}$	1 mark
$t = \frac{0.270}{\sqrt{1 - \frac{(0.650c)^2}{c^2}}}$	1 mark
$t = 0.355 \text{ s}$	1 mark

**Question 2**  
**marks)**

(6)

When an aeroplane needs to turn, it tilts its wings towards the centre of its turn at an angle 'θ' to the horizontal – see below).

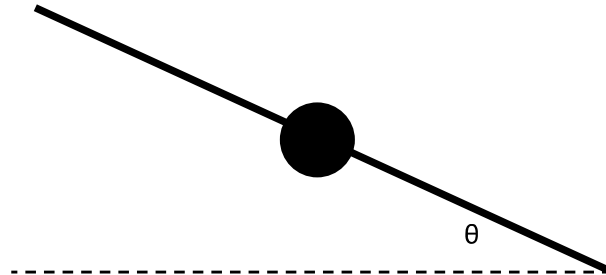

- (a) Explain why the aeroplane must tilt its wings in the manner described to complete the turn. As part of your answer, draw a vector diagram below to show the forces acting and the net force produced.

[3]

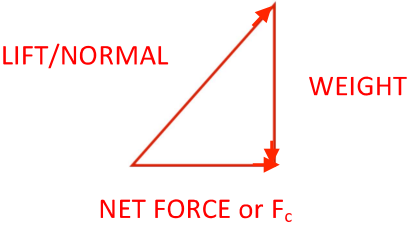
<p>All three forces are shown correctly (see diagram). Must overtly show that <math>F_c</math> is the Net Force.</p> 	1 mark
<p>All three forces are labelled correctly (see diagram).</p>	1 mark
<p>The net force (centripetal force) required for the turn is provided by banking.</p>	1 mark

- (b) The diagram above shows the angle 'θ' for a turn of a particular size of radius. Describe how the angle 'θ' would change if the aeroplane had to complete a turn with a smaller radius. Explain your answer using relevant Physics formulae.

[3]

$\tan \theta = \frac{F_c}{W}$	1 mark
$\tan \theta = \frac{mv^2}{r} / mg = \frac{v^2}{gr}$	1 mark

If  $r'$  decreases,  $\tan \theta$  and, hence,  $\theta$  increases.

1 mark

**Question 3**  
**marks)**

(3)

The diagram below shows a conducting loop carrying a current 'I'. The current flows in a clockwise direction and produces a magnetic field through the centre of the loop of strength 'B' Tesla.

The loop is already sitting in an existing external magnetic field of strength '2B' Tesla; this external field is directed into the page through the centre of the loop and is shown below.

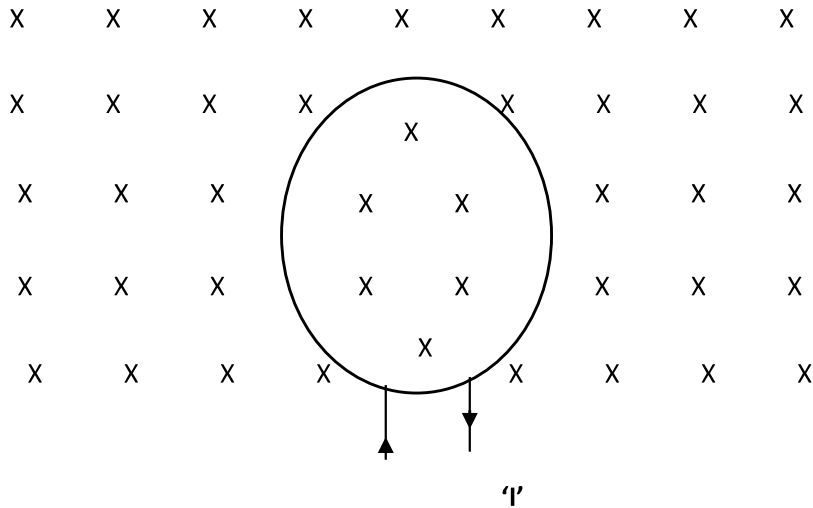

- (a) In terms of 'B', state the magnitude of the resultant field at the centre due to the external field and the field due to the current in the loop.

[1]

$\therefore \Sigma B = 2B + B; \therefore \Sigma B = 3B$	1 mark
--	--------

- (b) The current in the loop is doubled to '2I' (its direction is maintained as clockwise). In terms of 'B', state magnitude of the resultant field due to the external field and the current in the loop.

[1]

$\therefore \Sigma B = 2B + 2B = 4B$	1 mark
--------------------------------------	--------

- (c) The direction of the current in the loop is reversed while its magnitude is maintained as 'I'. In terms of 'B', state magnitude of the resultant field due to the external field and the current in the loop.

[1]

$$\therefore \Sigma B = 2B + (-B) = B$$

1 mark

**Question 4**  
**marks)**

(5)

A 50.0 kg uniform cantilever beam supports a 15.0 kg sign as shown below. The beam is 1.80 m long and the sign is suspended from its end as shown. A cable is also attached to the end of the beam and connects it to the wall. The cable makes an angle of 35° with the beam. The maximum tension the cable can withstand is 650 N.

Calculate the maximum distance from the wall the sign can be suspended before the cable will break. Ensure you illustrate all the forces acting on the beam in a free-body diagram.

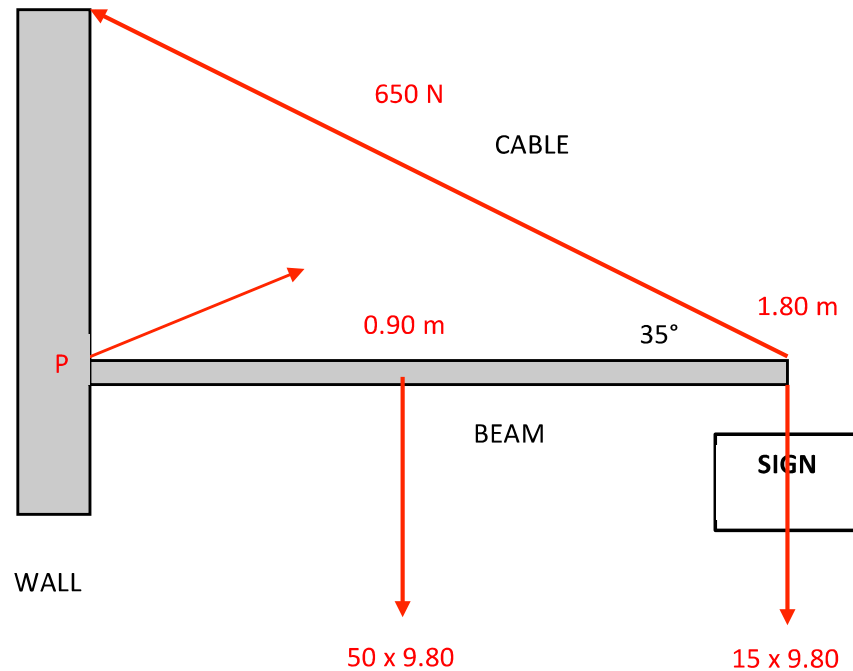

All four forces are shown in the correct locations.	1 mark
Take moments about 'P': $\Sigma M = 0$ ; $\Sigma M_C = \Sigma M_A$	1 mark
$(15.0 \times 9.80 \times r) + (50.0 \times 9.80 \times 0.90) = 650 \times 1.80 \times \sin 35^\circ$	2 marks
$\therefore r = 1.57 \text{ m}$	1 mark



**Question 5**  
**marks)**

**(6**

Recently, a Perth man pulled a dangerous stunt by stepping out of a moving train that was passing over the Fremantle Rail Bridge into the water about 8.50 metres below. As he fell, he experienced a horizontal displacement of 13.0 metres. See the figure below.

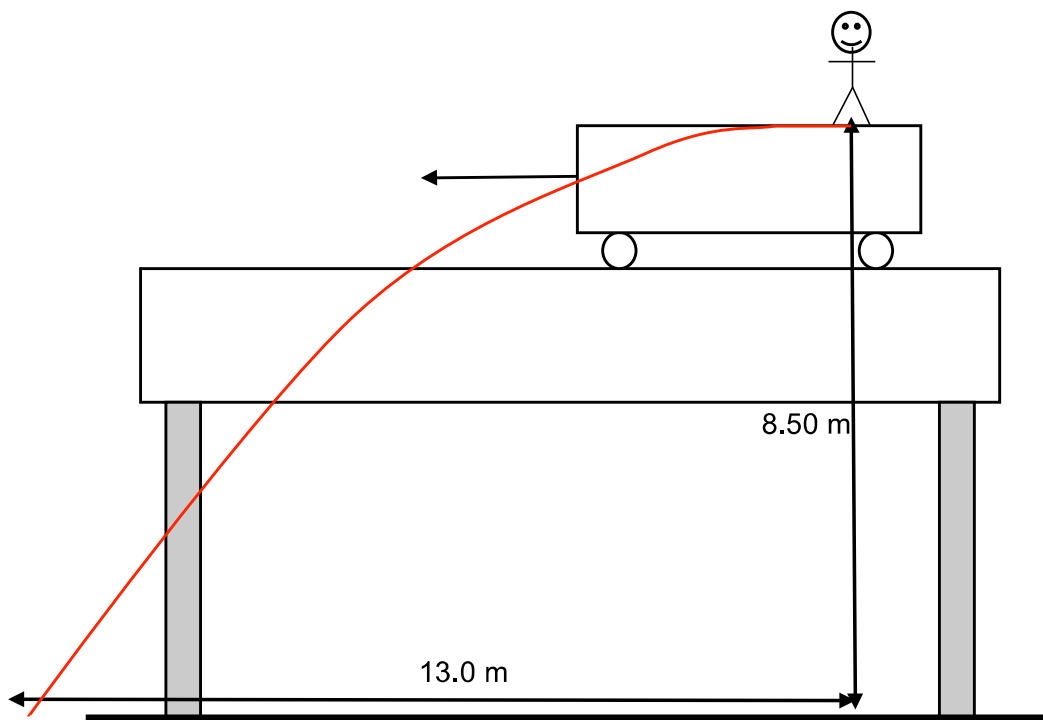

- (a) On the diagram above, draw the path taken by the man as he descends to the water. Air resistance can be ignored.

[2]

See diagram; Launch velocity is horizontal and path is parabolic.	1 mark
Lands at a horizontal distance of 13.0m	1 mark

- (b) Calculate the speed of the train when the man stepped out. The bridge can be assumed to be horizontal.

[5]

$u_H = ?; u_v = 0 \text{ m s}^{-1}$	1 mark
In the vertical plane; $s = ut + \frac{1}{2}at^2$ ; $8.50 = 0 \times t + \frac{1}{2} \times 9.80 \times t^2$ $t = \sqrt{\frac{8.50}{4.90}} = 1.32 \text{ s}$	1 mark
In the horizontal plane; $v = s/t; \therefore v = 13/1.32$	1 mark
$\therefore v = 9.87 \text{ m s}^{-1}$	1 mark

**Question 6**  
**marks)**

(6)

Two small, neutrally charged objects are placed 25.0 cm apart in air. Electrons are transferred from one object to the other until an electrostatic force of magnitude 0.500 N exists between the two objects.

- (a) Is the electrostatic force attractive or repulsive? Explain.

[3]

Attractive.	1 mark
Removing electrons creates a positively charged object. Adding electrons creates a negatively charged object.	1 mark
Unlike charges attract.	1 mark

- (b) Hence, calculate the size of the charge on each object that will create an electrostatic force of magnitude 0.500 N at this distance.

[3]

Both objects attain the same size charge; $q_1 = q_2 = q$	1 mark
$F = \frac{1}{4\pi\epsilon_0} \frac{q_1q_2}{r^2}$ ( $\epsilon_0 = 8.85 \times 10^{-12}$ ); $\therefore 0.500 = \frac{9 \times 10^9 \times q^2}{0.25^2}$	1 mark
$\therefore q_1 = q_2 = 1.86 \times 10^{-6} \text{ C}$	1 mark



**Question 7**  
**marks)**

(4

Here is an example of a particle interaction – the beta decay of a neutron that produces an anti-electron neutrino:

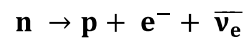

Complete the table below by adding the charge, baryon number and lepton number on each side of the equation (left-hand side ( $\Sigma$ LHS); right-hand side ( $\Sigma$ RHS)). State which Conservation Laws are either (i) observed; or (ii) violated. Show any working in the space below the table.

Conservation Law	$\Sigma$ LHS	$\Sigma$ RHS	Observed or violated?
Conservation of Charge (Q)	0	$1 + (-1) + 0 = 0$	Observed
Conservation of Baryon Number	1	$1 + 0 + 0 = 1$	Observed
Conservation of Lepton Number	0	$0 + 1 + (-1) = 0$	Observed

Charge calculations for $\Sigma$ LHS and $\Sigma$ RHS both correct.	1 mark
Baryon number calculations for $\Sigma$ LHS and $\Sigma$ RHS both correct.	1 mark
Lepton number calculations for $\Sigma$ LHS and $\Sigma$ RHS both correct.	1 mark
Conservation laws all observed.	1 mark

**Question 8**  
**marks)**

(4

An observer in a spacecraft A, which is moving at  $v = 0$ , observes another spacecraft B moving past them at  $0.900c$ .

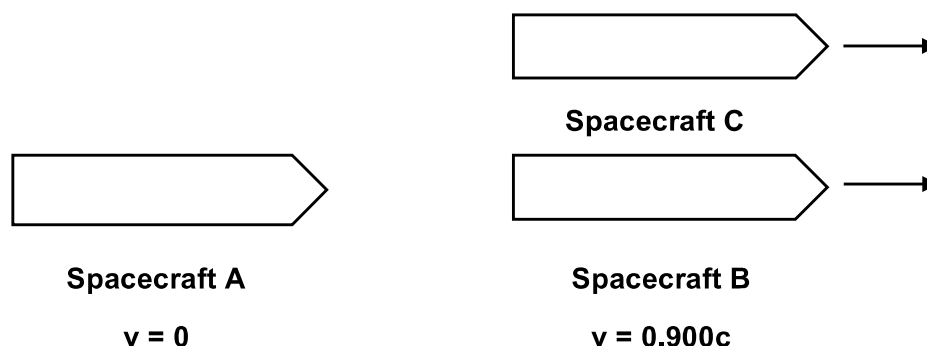

The observer also observes another spacecraft C moving at  $0.980c$  relative to their spacecraft A and in the same direction as spacecraft B.

Calculate (in terms of 'c') how fast spacecraft C is moving with respect to spacecraft B.

$u' = \frac{u - v}{1 - \frac{uv}{c^2}}; u = 0.900c, v = 0.980c$	1 mark
$u' = \frac{0.900c - 0.980c}{1 - \frac{(0.900c)(0.980c)}{c^2}}$	2 marks
$\therefore u' = -0.678c;$ ie – with respect Spacecraft B, the electron is travelling at $0.678c$ .	1 mark

**Question 9**  
**marks)**

(3

The windings on the primary and secondary coils of an ideal transformer number 50 turns and 500 turns respectively. The primary RMS input voltage is measured to be 16.0 V; the secondary RMS current is measured to be 200 mA. Calculate the power generated in the primary coil of this transformer.

$\frac{V_P}{V_S} = \frac{N_P}{N_S}; V_S = \frac{N_S \times V_P}{N_P} = \frac{500 \times 16.0}{50} = 160 \text{ V}$	1 mark
$P_P = P_S = V_S I_S = 160 \times 0.200$	1 mark
$\therefore P_P = 32.0 \text{ W}$	1 mark

**Question 10**  
**marks)**

(5

A positively charged droplet of oil enters a uniform electric field between two charged plates a distance of 25.0 cm apart. The plates are aligned horizontally. The droplet has a mass of 50.0 mg and possesses a charge of 10.0  $\mu\text{C}$ . Its path through the electric field is a horizontal straight line (see diagram below).

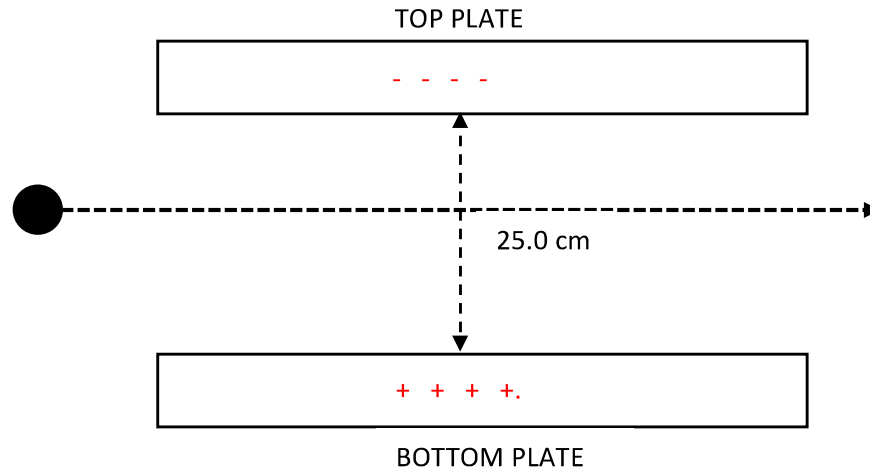

- (a) Use the data above to calculate the potential difference (V) between the two plates.

[4]

$F_e = mg = 50.0 \times 10^{-6} \times 9.80 = 4.90 \times 10^{-4} \text{ N}$	1 mark
$\therefore E = \frac{F_e}{Q} = \frac{4.90 \times 10^{-4}}{10.0 \times 10^{-6}} = 49.0 \text{ N C}^{-1}$	1 mark
$E = \frac{V}{d}; \therefore V = Ed = 49.0 \times 0.250$	1 mark
$\therefore V = 12.3 \text{ V}$	1 mark

- (b) Draw symbols on the plates to indicate their polarity.

[1]

Top plate is negative, bottom plate is positive.	1 mark
--	--------

**Question 11**  
**marks)****(5**

A pilot is navigating their jetfighter through a giant vertical circular loop.

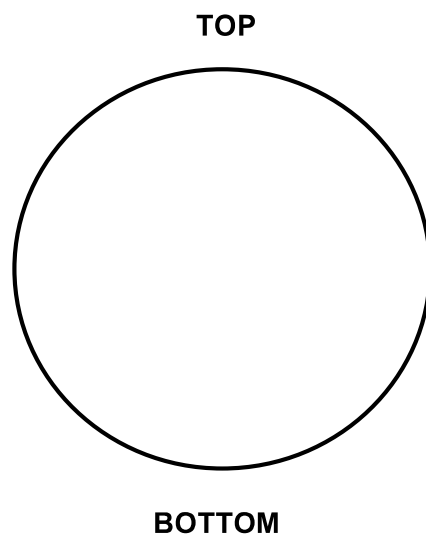

The pilot knows that at particular points on the vertical circular path, they will feel 'weightless'. At other points they will feel so heavy that they will experience G-forces that may cause them to pass out.

- (a) At which point (TOP or BOTTOM) will the pilot feel 'heaviest'? Explain.

[2]

BOTTOM	1 mark
$N = \frac{mv^2}{r} + mg; \therefore N > W$ <p>OR – the reaction force needs to counteract gravity as well as provide all of the centripetal force.</p>	1 mark

- (b) If the radius of the jetfighter's path is 1000m, at what speed would it have to be travelling for the pilot to feel absolutely weightless.

[3]

Weightless when $N = 0$	1 mark
$\text{At top, } N = \frac{mv^2}{r} - mg; \text{ when } N = 0, v = \sqrt{gr}$ <p>;</p>	1 mark
$\therefore v = \sqrt{9.8 \times 1000} = 99.0 \text{ ms}^{-1}$	1 mark





**Question 12**  
**marks)****(4**

Estimate the gravitational force between two Year 12 Physics students sitting next to each other at school desk.

$m_1$ and $m_2$ are between 40 kg and 100 kg; $r$ is between 0.30 m and 1.00 m	1 mark
$F_g = \frac{Gm_1m_2}{r^2}$	1 mark
$\therefore F_g$ is between $1 \times 10^{-7}$ N and $7 \times 10^{-6}$ N	1 mark
Answer is to 1 or 2 significant figures.	1 mark

